

PIROS[®] Infrared Sensors

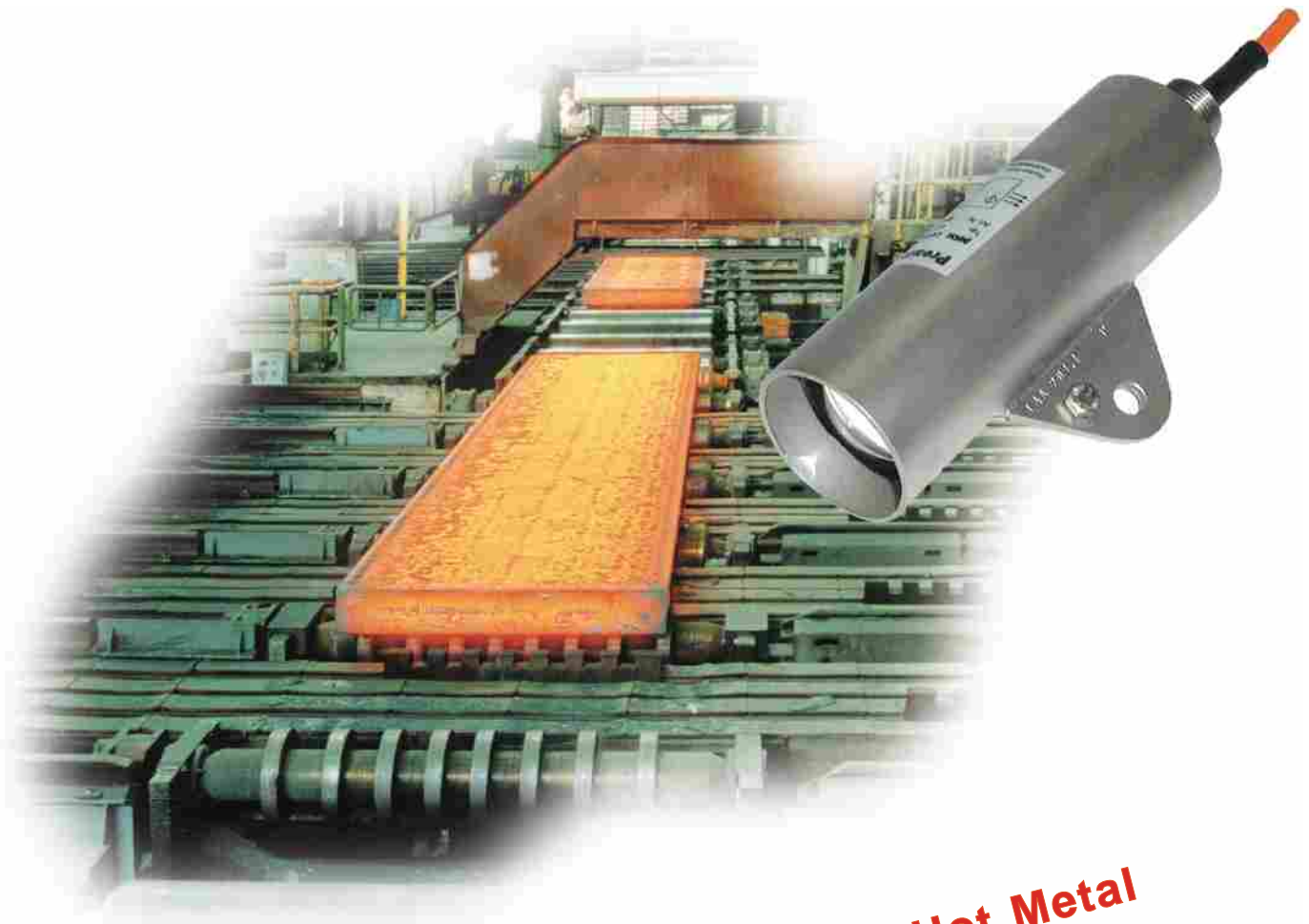

**Hot Metal
Detection**

**Material tracking in steel and rolling mills
Press control and glass industry**

Infrared-sensors detect the infrared radiation emitted by hot materials and transform it into an electrical signal.

Built-in optics to narrow the field of view, combined with a predetermined switching temperature, provide for a wide range of applications. These include precise location and positioning of hot objects in, for example, steel and rolling mills, forges and foundries, and glass and ceramic installations. Hot parts can be tracked over distances of several metres, flames monitored, or mould part removal of hot objects checked.

The line includes compact versions with integrated processing electronics as well as models for ambient temperature of up to +290 °C, with fibre optic cable between the optics and the electronics. All components are housed in rugged stainless steel and fully potted for protection against moisture, steam, shock and vibration. Optical filters protect against spurious radiation.

The electrical versions are available as 3-wire types for 10 - 55 V DC and 2-wire types for 20 - 260 V AC/DC. Both versions are completely protected against short circuit, overload and polarity reversal. The pulsing short-circuit protection with high interference immunity provides automatic reset after the fault is removed. A built-in LED indicates the operating condition. Connection is via 2 m POKT-Therm cable or rugged connector with IP68 rating.

Angle of View, Distance Ratio

The scanned surface diameter (d) increases with increasing distance (s). This distance relationship is dependent on the angle of view (α).

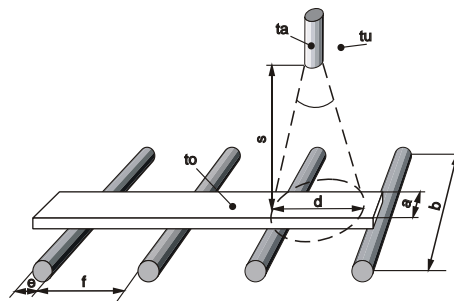
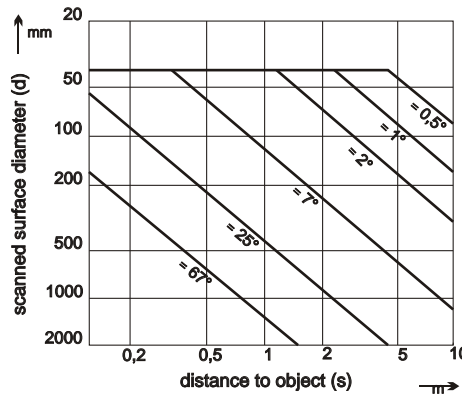

Incomplete Coverage

Sometimes the field of view of the PIROS is not entirely filled by the object. In such cases the sensor must have a lower response temperature. For example, if the object coverage is only 40% (10%) use a version that is 50 K (160 K) more sensitive.

Surface Finish, Emissivity

Most of the applications described in this brochure refer to materials having a rough, black or oxidized surface. In these cases the emissivity is nearly 1 and can thus be ignored. However, a bright, specular surface with emissivity of <0.1 renders any noncontact measurement more difficult.

Changing Conditions of Operation

Increasing flexibility in production lines requires highly adaptable sensors. An ideal application for PIROS with adjustable and self-learning response temperature. The sensors can react to changing object shapes or different temperatures.

Options + Accessories

Function Check:

An automatic or manual self-check is effected by remote control.

Cooling Jacket:

Double-wall stainless steel casing for water cooling.

Air connection:

For blowing compressed air to keep the optics clean of dust, water vapour and heat radiation.

Tube:

Accessories for limiting the field of view, as protection from other influencing factors.

Swivel Stand:

Accessory for simple mounting and adjustment.

Electronic Aiming Device:

An LED chain for exact aiming at the measuring surface. Recognizes safety reserve in case of background radiation.

Analogue Output:

0 - 10 V or 0 - 20 mA corresponding to the object temperature between 400 - 950 °C.

OKD/OSD:

PIROS in painted aluminium rectangular housing with clamp connection for applications outside of the harsh steel and rolling mill area.

LSA/LRA:

Light barriers in stainless steel housings for steel and rolling mills, e.g. for material tracking in an annealing furnace.

Teach-In:

A process-optimised algorithm allows variable conditions.

Piros compact (integrated evaluating electronics)

Field of view:

0.5°, 1°, 2°, 7°, 2°x25°

Fixed response temperature:

350, 430, 650, 800 °C

Variable response temperature:

300 to 900 °C
adjustable or Teach-In



OKA

Compact sensor with stainless steel housing with 57 mm Ø, for ambient temperatures up to +75 C



OKB

Compact sensor with stainless steel housing with 78 mm Ø and cooling water connection for ambient temperatures over +75 C

An object is signalled if the surface scanned completely fills the field of view and the temperature is higher than the response temperature. For sensors with a fibre optic cable the response temperature depends on the length of the fibre optic cable and the lens used.

Piros with fibre optic cable



OSA

Evaluating electronics with stainless steel housing with 57 mm Ø, for ambient temperatures up to +75 C

Connections:

10 - 55 V DC,
3-wire PNP normally open or
4-wire PNP normally open and
closed,

20 - 260 V AC/DC,
2-wire normally open or closed



OSB

Evaluating electronics with stainless steel housing with 78 mm Ø and cooling water connection for ambient temperatures over +75 C

Angle of view, response temperature and mode of operation can be combined as required.

The model identification code indicates the characteristics of the sensor.

For example: OKA 204.05 G:

OKA Compact sensor OKA
2 2° lens
04 450 °C
response temperature
.05 G 20 - 260 V AC/DC,
2-wire closer



LLK

The evaluating electronics described above require a fibre optic cable and a lens. Rugged fibre optic cables with stainless steel sheathes are available in different lengths.

Lenses with stainless steel housings for various fields of view and shapes are available for different applications.



OAA



OAF



OAC

PIROS® Infrared - Sensors

For over 20 years PIROS infrared sensors have been used successfully even under extreme conditions in steel works, rolling mills, hot pressing installations and glass manufacturing industries. Rugged mechanical, optical and electrical construction is a major precondition for reliable signals in material tracking for automation purposes. Piros sensors are used in applications ranging from continuous casting to hot rolling of strips, sheets, wires and pipes to the finishing work on the final products.

**Use sensors to solve automation problems:
Contact us!**

Besides standard solutions we have many answers to suit your special requirements.

We will be pleased to advise you!

Applications

- **Mould level monitoring**
- **Welding blowpipe control in slab strand cut-off machines**
- **Roller table control**
- **Slab edge detection**
- **Measurement of rolling stock in the roll gap**
- **Loop and reeling plant control**
- **Length measurement**
- **Wire rupture control**
- **Mould part removal monitoring in presses or in the glass and ceramics industries**
- **Inductive hardening**
- **Monitoring of excess burner and welding flame**
- **Descaling plants**
- **Slab marking**

Product range

Inductive proximity switches

- WG 210 Sensing distance < 20 mm
- WG 220 Sensing distance 20-60 mm
- WG 230 Sensing distance 60-120 mm
- WG 240 Sensor strips
- WG 241 Flat sensors
- WG 250 Ring sensors
- WG 260 Inductive analogue sensors and evaluating electronics

Other sensors

- WG 100 Capacitive sensors
- WG 510 Piros light barriers
- WG 610 Piros infrared sensors
- WG 620 Piros for fibre optic cables
- WG 800 Flow sensors for air
- WG 830 Flow sensors

www.proxitron.de



Proxitron
SENSOREN FÜR AUTOMATION

PROXITRON GmbH
INDUSTRIELEKTRONIK
GÄRTNERSTRASSE 10
D-25335 ELM SHORN
TEL. +49 (0)4121/2621-0
FAX. +49 (0)4121/24404
mail@proxitron.de
www.proxitron.de